

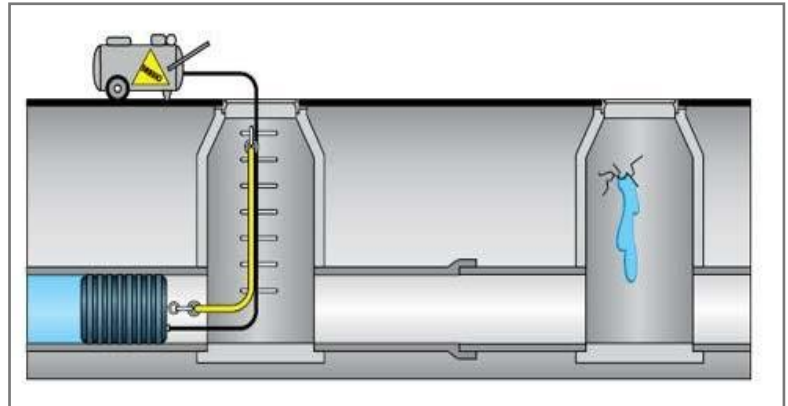

INFLOW & INFILTRATION REDUCTION PROGRAM: OVERNIGHT WASTEWATER FLOW ANALYSIS

The City of Fort Lauderdale is working with Ardurra Group Inc. to study the flow of wastewater throughout the City's sewer system over the next three years. This flow analysis is part of the City's ongoing efforts to identify portions of the sewer system where stormwater and groundwater are possibly entering the system, which leads to problems such as increased treatment cost and reduced system capacity. The results of this analysis will be used to plan future sewer system improvement projects.



This work began on Sunday, July 21, 2024, and the current phase is expected to be completed in November 2024. This schedule is subject to change based on inclement weather or other unforeseen circumstances. Inspections will take place Sunday through Thursday evenings between 11 p.m. and 7 a.m. During this time, most neighbors are sleeping, meaning that flows in the system are likely due to infiltration of groundwater or stormwater through defective sewer pipes and structures.

Crews will be accessing sewer lines through sewer manholes. Therefore, no heavy machinery will be on site and minimal noise and lighting impacts are expected.

Approximate Schedule

Thurs., Sept. 5 – Wed., Sept. 11

Coral Ridge Isles, Imperial Point & Boulevard Park Isles

Thurs., Sept. 12 – Tues., Sept. 17

Lake Estates, Bay Colony & Bay Colony Club

Wed., Sept. 18 – Tues., Oct. 1

Coral Ridge Country Club Estates & Coral Ridge

Wed., Oct. 2 – Tues., Oct. 15

Imperial Point, Boulevard Park

Isles & Knoll Ridge

Wed., Oct. 16 – Tues., Oct. 29

Knoll Ridge, North Golf Estates, Landings & Coral Ridge Country Club Estates

Wed., Oct. 30 – Tues, Nov. 6

Sunrise Intracoastal & Coral Ridge

Wed., Nov. 7 – Sun., Nov. 17

Victoria Park

Traffic Impacts

- One lane in each direction of neighborhood streets may be closed temporarily during work hours. Traffic control personnel will direct traffic as needed.
- Access to driveways will be maintained.
- Please follow posted signs and drive with caution in the area.

We apologize in advance for any inconvenience and thank our neighbors for their patience while we complete this important analysis.

To see a map of the areas where night flow isolation is scheduled and learn more about the City's efforts to reduce inflow and infiltration, visit ftlcity.info/iandi.

For more information or questions, contact:

Inflow and Infiltration Program Hotline

877-332-4037 or ftlii@ardurra.com

If you would like this publication in an alternate format, please call 954-828-4755 or email strategiccommunications@fortlauderdale.gov.

